

AZUR CONNECTORS, DRAINAGE AND SEPTIC TANK SEALS

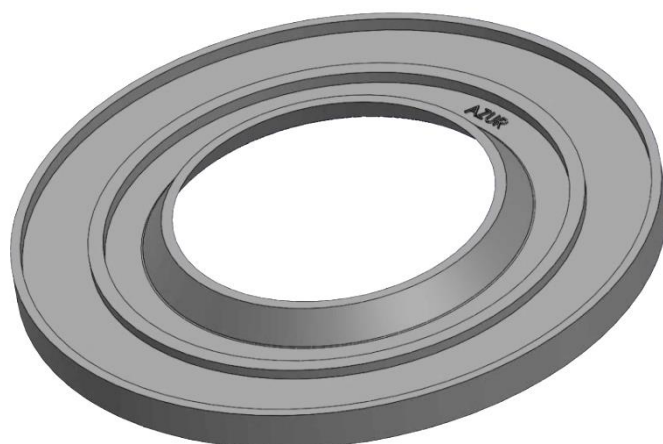

2017

RELIABLE.

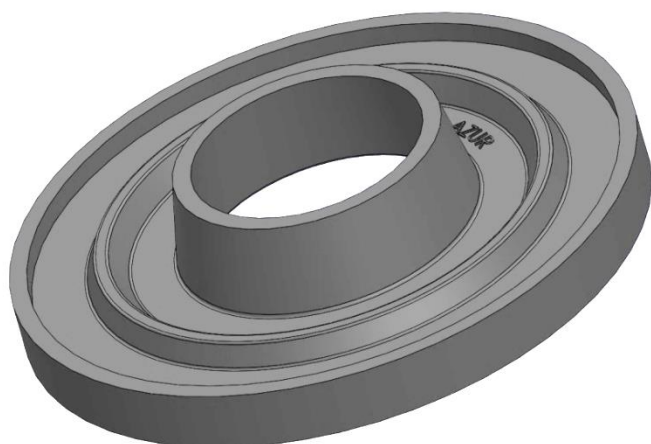

SPLIT VIEW - CONNECTOR



SPLIT VIEW – SEPTIC TANK SEAL



SPLIT VIEW – DRAINAGE SEAL

AZUR CONNECTORS

PIECE NO.	INT. DIMENSION OF PIPE	QTY / BOX*
CA-100-4	100mm (4in)	100
CA-150-6	150mm (6in)	100
CA-200-8	200mm (8in)	65
CA-250-10	250mm (10in)	40
CA-300-12	300mm (12in)	40
CA-445-17	445mm (17.5in)	24

NITRILE AND OTHER DIMENSIONS AVAILABLE. CONTACT US!

*MINIMUM QTY OF ONE BOX PER ORDER

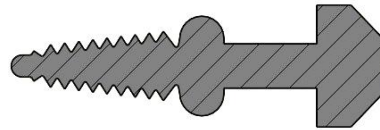

CONNECTOR PROFILE

www.azurcaoutchouc.com

AZUR DRAINAGE AND SEPTIC TANK SEALS

PIECE NO.	INT. DIMENSION OF PIPE	QTY / BOX*
JIP-3-4-AZ	75-100mm (3-4in) <u>(septic tank)</u>	80
JIP-6-AZ	150mm (6in) <u>(drainage)</u>	100
JIP-8-AZ	200mm (8in) <u>(drainage)</u>	70

NITRILE AND OTHER DIMENSIONS AVAILABLE. CONTACT US!

*MINIMUM QTY OF ONE BOX PER ORDER

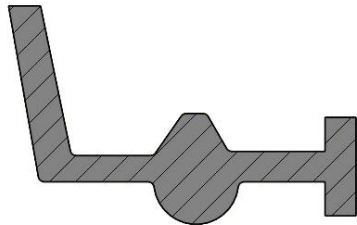

SEPTIC TANK SEAL PROFILE

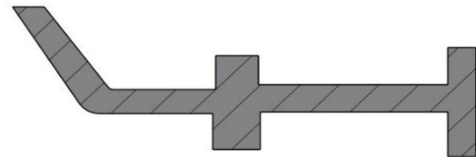

DRAINAGE SEAL PROFILE

www.azurcaoutchouc.com

PHYSICAL CHARACTERISTICS
OF AZUR RUBBER SEALS

BNQ NQ2622-420/2009 B ANNEX

PHYSICAL TEST	ASTM TEST #	REQUIRED RESULTS :	GIVEN RESULTS
		ASTM C923M BNQ 2622-420	
HARDNESS SHORE TYPE A	D-2240	56 ±5 DURO	56 DURO
TENSILE STRENGTH	D-412	MIN 8.5 MPa	11.03 MPa
ELONGATION AT BREAK	D-412	MIN 350%	429%
HEAT AGING (70H @ 70°C)	D-573		
- TENSILE STRENGTH CHANGE - ELONGATION CHANGE		MAX -15% MAX -20%	-5.30% -13.24%
COMPRESSION SET (22H @ 70°C)	D-573 METHODE B	MAX 25%	12.97%
WATER ABSORPTION (48H @ 70°C)	D-471	MAX 10%	1.23%
OZONE RESISTANCE TO 25 PPHM (48H @ 40°C) WITH 20% STRAIN	D-1149	CLASSE 0	NO RIPPING
LOW TEMPERATURE BRITTLENESS (-40°C)	D-2137	NO RIPPING	NO RIPPING
TEARING RESISTANCE	D-624 DIE B	MIN 34 KN/m	36.8 KN/m

www.azurcaoutchouc.com